

UCESB

unpack & check every single bit

A generic tool for reading DAQ/online data

```
SUBEVENT(FASTBUS_CRATE)
```

```
{
```

```
  select several
```

```
  {
```

```
    adc0 = LECROY_1885(geom=10, channels=96);
```

```
    qdc[0] = LECROY_1885(geom=13, channels=48);
```

```
    qdc[1] = LECROY_1885(geom=17, channels=48);
```

```
    qdc[2] = LECROY_1885(geom=15, channels=48);
```

```
  }
```

```
}
```

Unpacking for
DAQsters

Håkan T. Johansson, Chalmers, Göteborg

GSI, Darmstadt, February 2010

Primary scope of program

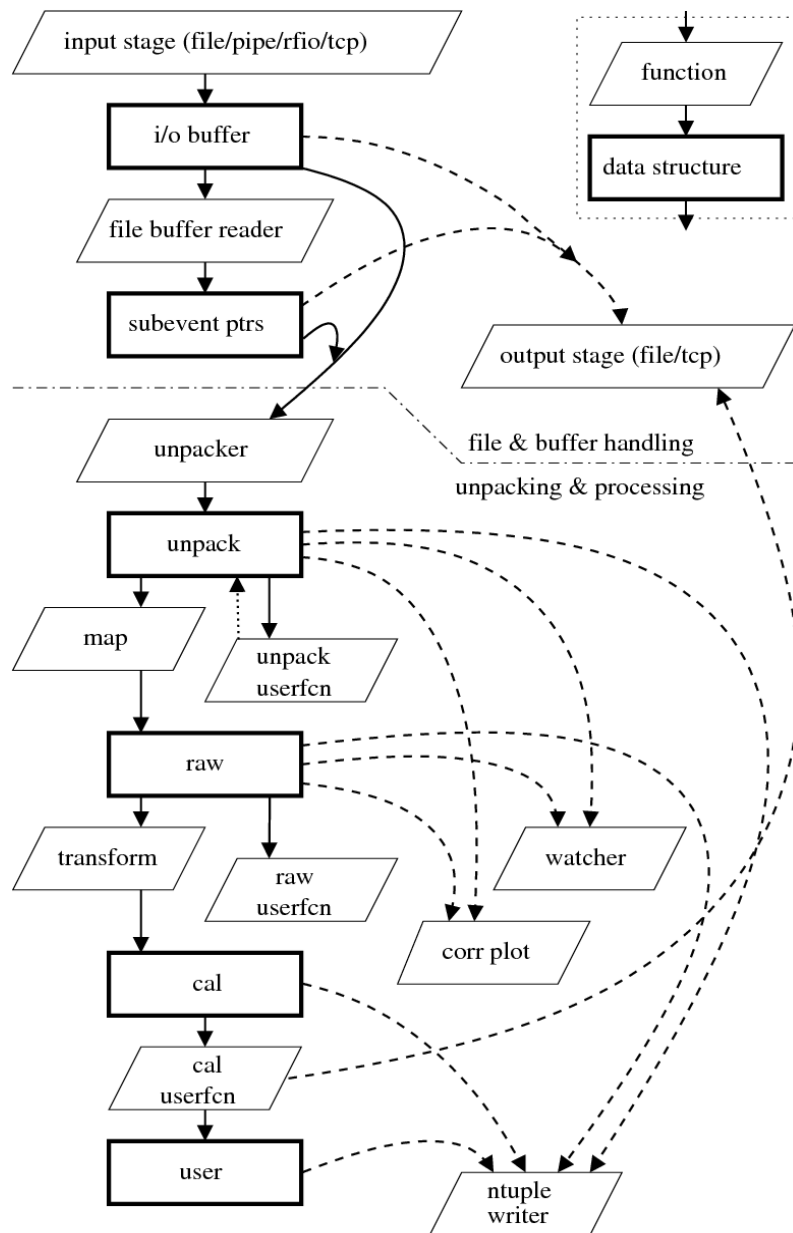

'Quick-n-dirty' generic unpacking and data 'quality' monitor

Unpack code generation from C structure-like **specification**:

```

SUPER_TDC(slot)
{
    UINT32 value;
}
SUBEVENT(ONE_CRATE)
{
    tdc1 = SUPER_TDC(slot=5);
    tdc2 = SUPER_TDC(slot=6);
}
EVENT
{
    crate1 = ONE_CRATE(type=5);
}
    
```

ucesb/(land02) interaction

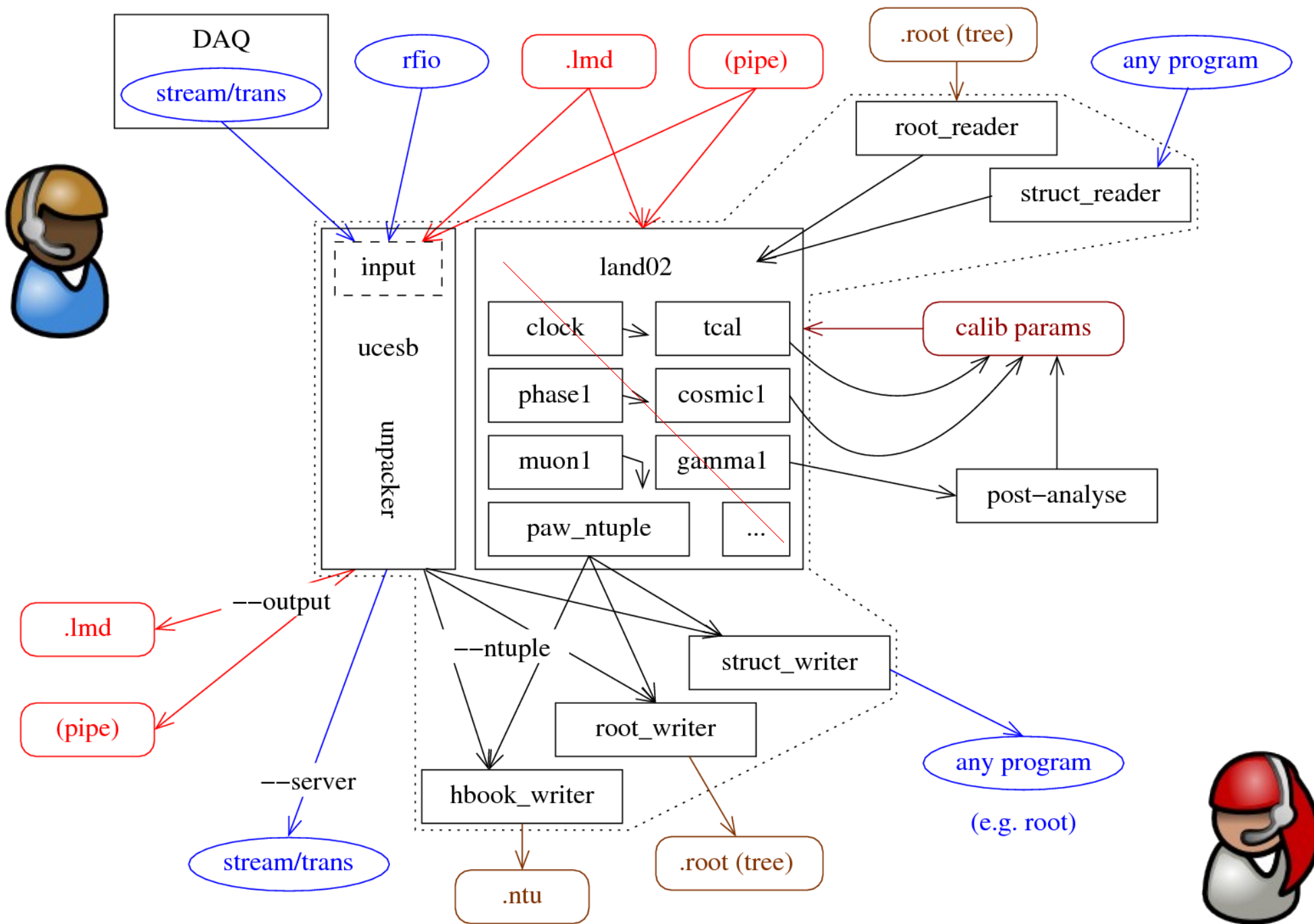

Command line driven

Compile:

```
make land  
make land USE_EXT_WRITER=1 USE_CURSES=1
```

Run:

```
land/land /misc/scratch.land1/s245/lmd/r06_0308.lmd
```

Append options to manipulate the data:

```
--ntuple=RAW,r06_0308.ntu or --ntuple=RAW,r06_0308.root
```

More manipulations:

```
--watcher=POS1-2_1-4T:POS1-2_1-4E,N1_1-5_1-2T
```

List available options:

```
land/land --help
```

Command line – Input options

<code>file://SRC</code>	Read from file SRC.
<code>rfio://HOST:SRC</code>	Read from rfio file SRC from HOST.
<code>event://HOST</code>	Read from event server HOST.
<code>stream://HOST</code>	Read from stream server HOST.
<code>trans://HOST</code>	Read from transport HOST.
<code>--in-tuple=LVL,DET,FILE</code>	Read data from ROOT-file/STRUCT. (new)
<code>--scramble</code>	Toggle scrambling of data.
<code>(--merge)</code>	No support for overlapping sources compiled in.

Normal files can also be given just by name or `--file=`
For pipelines, `-` is treated as STDIN

RFIO will check and enforce that the files are staged

Read data **on-line** from MBS (or proxy) **network servers**

Insert data from **ROOT-files**, or (any) **external program**

(un)scrambling of 16 and 8-bit entries (usually NOT needed)

Sort the events from several files from **multi-EB** mode.

Command line – Input Diagnostics

```
--print-buffer  
--print  
--data  
--dump=LVL  
--event-sizes
```

Print buffer headers.
Print event headers.
Print event data.
Text dump of data from data structures.
Show average sizes of events and subevents.

Print file & buffer headers:

```
Buffer      0, Size 16384 Used      0 Thu 1970-01-01 00:00:00.000 UTC  
Events     0 Type/Subtype 2000    1 FragEnd=0 FragBegin=0 LastSz    0  
File header:  
Label      R06  
File       R06_0308.LMD  
User       land  
Time       27-Sep-01 09:13:59  
Run  
Exp  
Buffer    1082774, Size 16384 Used 10032 Thu 2001-09-27 07:13:46.905 UTC  
Events    3 Type/Subtype 10      1 FragEnd=0 FragBegin=0 LastSz 1444  
Buffer    1082775, Size 16384 Used 15868 Thu 2001-09-27 07:13:47.023 UTC  
Events    4 Type/Subtype 10      1 FragEnd=0 FragBegin=0 LastSz 1456
```

Print event & sub-event headers:

```
Event      7938336 Type/Subtype 10      1 Size 1444 Trigger 1  
SubEv ID   1 Type/Subtype 34 3100 Size 384 Ctrl 9 Subcrate 0  
SubEv ID   1 Type/Subtype 34 3200 Size 216 Ctrl 9 Subcrate 0  
SubEv ID   1 Type/Subtype 32 3100 Size 800 Ctrl 0 Subcrate 0  
Event      7938338 Type/Subtype 10      1 Size 412 Trigger 7  
SubEv ID   1 Type/Subtype 34 3100 Size 392 Ctrl 9 Subcrate 0
```

Print **unpacked & mapped data...**
(not shown)

0xHEX-dump the raw data:

```
Event 270987188 Type/Subtype 10      1 Size 404 Trigger 2  
SubEv ID 1 Type/Subtype 34 3200 Size 8 Ctrl 9 Subcrate 2  
02000000 00004321  
SubEv ID 2 Type/Subtype 32 3130 Size 96 Ctrl 9 Subcrate 1  
28190afi 281c0a73 50910145 5096013e 5099016e b8b00157 68c00103 68c1014c  
68c2014a 68c3016a 68c40101 68c50142 68c60102 68c70129 68c80129 68c90144  
68ca0129 68cb0126 68cc013c 68cd0162 68ce011b 68cf0164 40b10240 40b4017a  
...
```

```
type/stype  id crt ctrl  min  max  avg(ev) avg(tot) head  occurrences  
trig 1:  
34/ 3100   10: 2: 1 ( 384 384) 384.0 19.0 0.6 ( 390)  
32/ 3130    8: 1: 2 ( 4 1516) 180.5 180.5 12.0 ( 7885)  
32/ 3130    8: 2: 2 ( 8 1368) 19.8 19.8 12.0 ( 7885)  
34/ 3200   10: 2: 1 ( 124 124) 124.0 124.0 12.0 ( 7885)  
34/ 3500   10: 2: 1 ( 4 64) 8.0 8.0 12.0 ( 7885)  
82/ 8200   10: 0: 3 ( 3320 3960) 3479.0 3479.0 12.0 ( 7885)  
...  
trig 2:  
34/ 3100   10: 2: 1 ( 384 384) 384.0 19.2 0.6 ( 177)  
32/ 3130    8: 1: 2 ( 0 1048) 41.8 41.8 12.0 ( 3549)
```

Generate **summary** of event & sub-event **sizes** vs. trigger type

Command line – Processing & Monitoring

```
--watcher=DET  
--corr=TRIG,DET,FILE
```

Do ncurses-based data viewing.
Create 2D correlation plot.

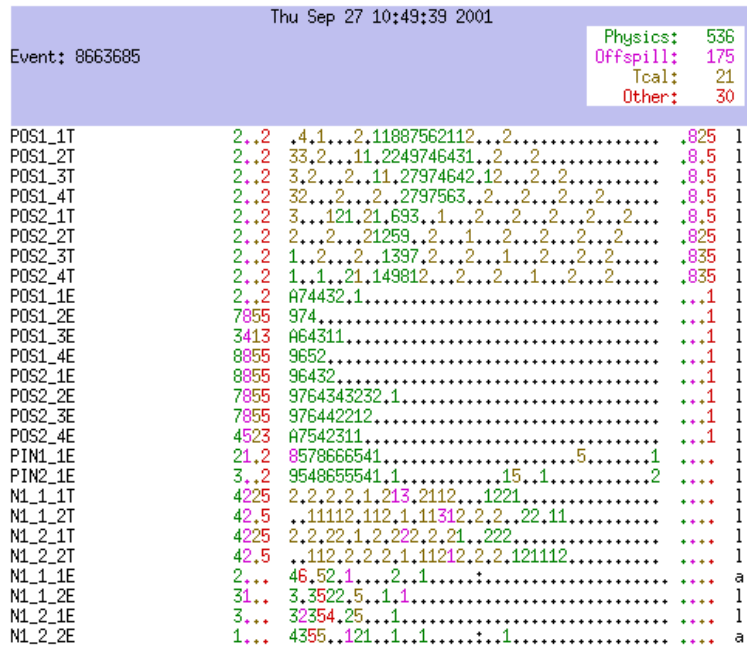

DAQ-scope:

On/off-line 'movie' view of data
Shows usage of each channel's range

Usually 1 spill per 'frame'

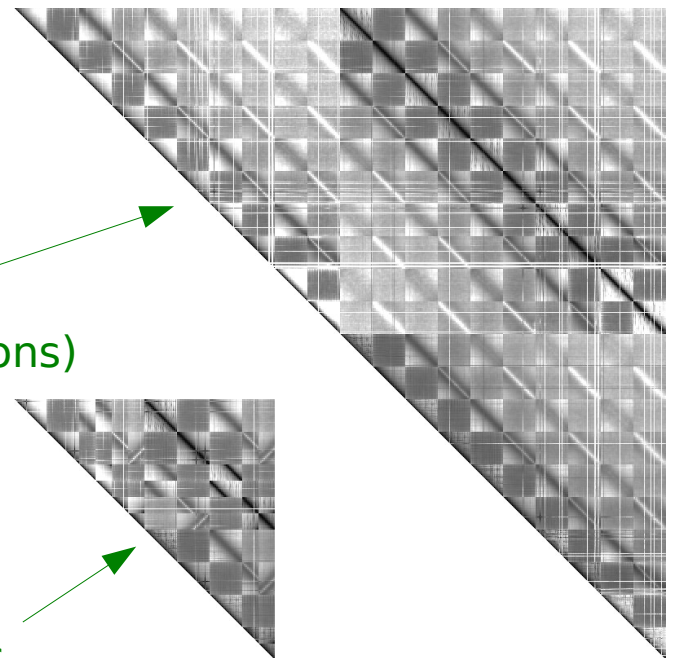

LAND
(cosmic muons)

artificial mismaps

Correlations between data in neighbouring channels checks mapping

UCESB – unpack & check every single bit

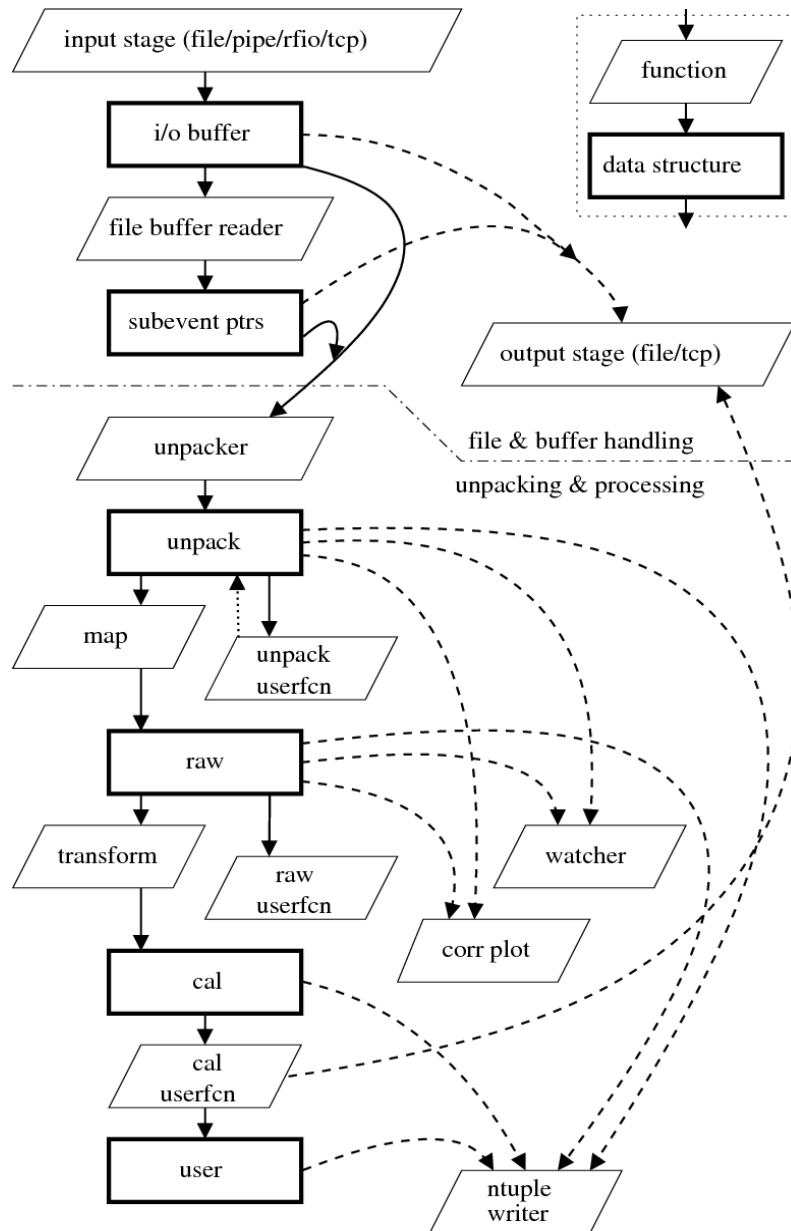

'Quick-n-dirty' generic unpacking and data 'quality' monitor

Unpack code generation from C structure-like **specification**:

```
SUPER_TDC(slot)
{
    UINT32 value;
}
SUBEVENT(ONE_CRATE)
{
    tdc1 = SUPER_TDC(slot=5);
    tdc2 = SUPER_TDC(slot=6);
}
EVENT
{
    crate1 = ONE_CRATE(type=5);
}
```

<http://fy.chalmers.se/~f96hajo/ucesb/>

Module .spec structure

CAEN V775 (TDC) data format:

```

VME_CAEN_V775(geom,crate)
{
  MEMBER(DATA12_OVERFLOW data[32] ZERO_SUPPRESS);

  UINT32 header NOENCODE {
    8_13: count;
    16_23: crate = MATCH(crate);
    24_26: 0b010;
    27_31: geom = MATCH(geom);
  }

  list(0<=index<header.count) {
    UINT32 ch_data NOENCODE {
      0_11: value;

      12: overflow;
      13: underflow;
      14: valid;

      16_20: channel;

      24_26: 0b000;
      27_31: geom = CHECK(geom);

      ENCODE(data[channel], (value=value,overflow=overflow));
    }
  }

  UINT32 eob {
    0_23: event_number;
    24_26: 0b100;
    27_31: geom = CHECK(geom);
  }
}

```

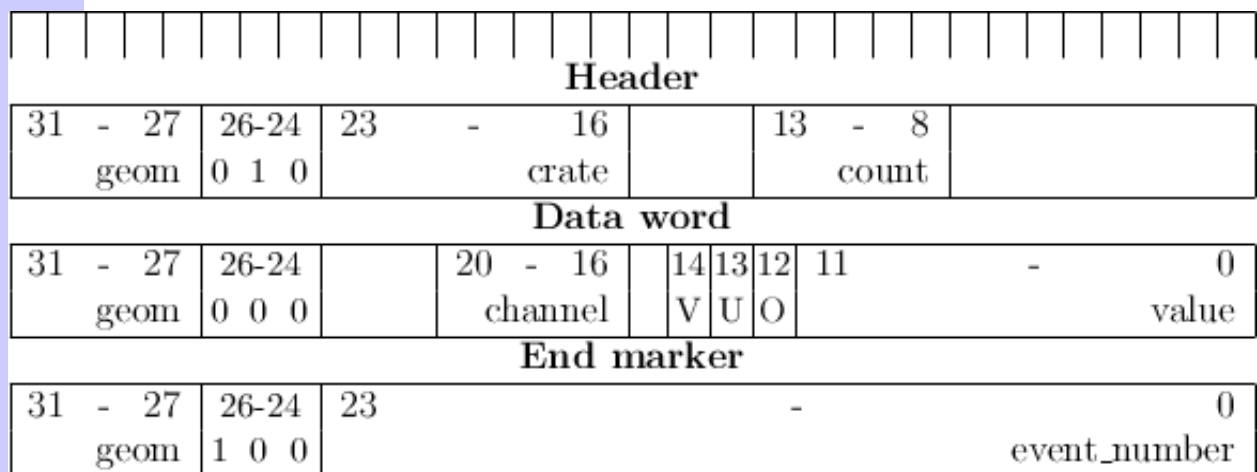

.spec: item blocks, SUBEVENT, EVENT

'Object oriented' – structures in structures

```
SUPER_TDC(slot)
{
  UINT32 value;
}

SUBEVENT(ONE_CRATE)
{
  tdc1 = SUPER_TDC(slot=5);
  tdc2 = SUPER_TDC(slot=6);
}

EVENT
{
  crate1 = ONE_CRATE(type=5);
}
```

```
class SUPER_TDC
{
  uint32 value;
};
class ONE_CRATE
: public unpack_subevent_base
{
  SUPER_TDC tdc1;
  SUPER_TDC tdc2;
};
class unpack_event
: public unpack_event_base
{
  ONE_CRATE crate1;
};
```

.spec: select several

When (several) blocks/items occur in arbitrary order:

select
select several

Then usually **MATCH** within the blocks

```
class LECROY_1885
{
    // ...
};
class FASTBUS_CRATE
    : public unpack_subevent_base
{
    LECROY_1885 adc0;
    LECROY_1885 qdc[3];
};
```

```
SUBEVENT(FASTBUS_CRATE)
{
    select several
    {
        adc0 = LECROY_1885(geom=10, channels=96);
        qdc[0] = LECROY_1885(geom=13, channels=48);
        qdc[1] = LECROY_1885(geom=17, channels=48);
        qdc[2] = LECROY_1885(geom=15, channels=48);
    }
}
```

.spec: bitfields

```
BITFIELD()  
{  
  UINT16 data  
  {  
    0_11: value;  
    12_14: channel;  
    15: overflow;  
  }  
}
```

```
class BITFIELD  
{  
  union  
  {  
    struct  
    {  
      uint16 value:12;  
      uint16 channel:3;  
      uint16 overflow:1;  
    };  
    uint16 u16;  
  } data;  
};
```

Bit-packed items are specified with their locations

Generated as bit-fields
(actually twice, for big and little endian unpacker program host *machines*
- i.e. this is not the byte-swapping;
it is C bit-field declaration conventions)

Access to the **full word**

Input stage, etc...

Techno-babble...:

Zero copy (unpack directly from `mmap()`ed **I/O-buffers**)
(only fragmented *subevents* are copied)

Byte-swapping on the fly - **templated** unpacker functions

Event-driven

Separate **thread** for **network input**

Transparent **fork** of `gzip` / `gunzip` / `bzip2` / `bunzip2` / `Izma`

Bucket-sort strategies for mapping – **fixed size** structures
(as default)

Separate **thread** for **network output**

ntuple / **ROOT tree** / **struct** writer as separate **process**

File formats

Common code for low-level I/O-buffers

Several file packaging readers (buffers etc):

LMD – .lmd – list mode data (**GSI** standard)

PAX – **KVI** data (**ESN** unpacking)

EBYEDATA – (Daresbury) **MIDAS**

HLD – **Hades** files

(more - easily possible... **suggestions?** (i.e. have any interesting **files?**))

Event handling (including unpacking) is common code

Mapping modules to detectors

Each signal mapping has a **source** at UNPACK level, a **destination** at RAW level, and a **type** (same as at UNPACK)

Corresponding C structure is generated

```
struct raw_event_DETA
{
    DATA12 T[2];
    DATA12 E;
};
struct raw_event_DET B
{
    DATA12 T;
};
struct raw_event
: public raw_event_base
{
    raw_event_DETA DETA[1];
    raw_event_DET B DETB[5];
};
```

```
// Declarations of single detector signals
SIGNAL(DETA_1_T2, vme.tdc[1].data[6], DATA12);
SIGNAL(DETA_1_E, vme.qdc[2].data[12], DATA12);

// Create an item in the raw level without source
SIGNAL(DETB_5_T, , DATA12);
```

CAL level and units

```
struct raw_event_DETD
{
    DATA12 E UNIT ("ch");
};
struct raw_event
    : public raw_event_base
{
    raw_event_DETD DETD[1];
    DATA32 SCALER[1];
};
```

Optional units
for the conversions

```
struct cal_event_DETD
{
    float E UNIT ("#MeV");
};
struct cal_event
    : public cal_event_base
{
    cal_event_DETD DETD[1];
};
```

CAL level has same layout
as RAW level

```
// An item with cal level entry, and units
SIGNAL(DETD_1_E, vme.qdc[3].data[0], (DATA12 "ch", float "#MeV"));

// An item which is only mapped for the last physical event in a
// multi-event unpacker
SIGNAL(LAST_EVENT: SCALER_1, vme.scaler.data[0], DATA32);
```

Data structures

“Show me your **code** and conceal your **data structures**, and I shall continue to be **mystified**. Show me your **data structures**, and I won't usually need your **code**; it'll be **obvious**.”

Eric Raymond

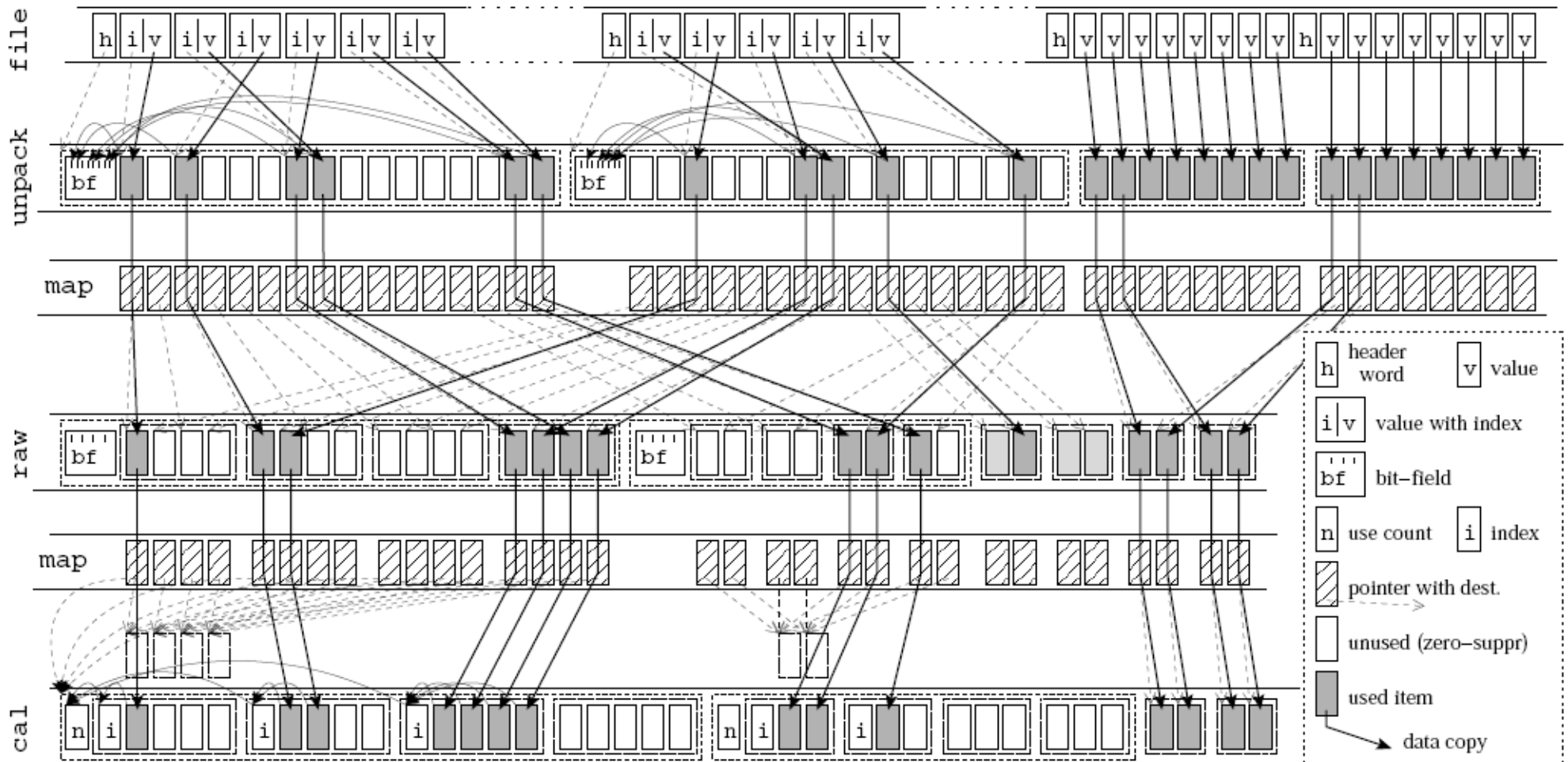

Code generation & compilation

Use the compiler - that's what it is for!

Build process handled by a Makefile

Just type: make

The compilation **guitar** - the *only* 'GUI' ucesb needs.

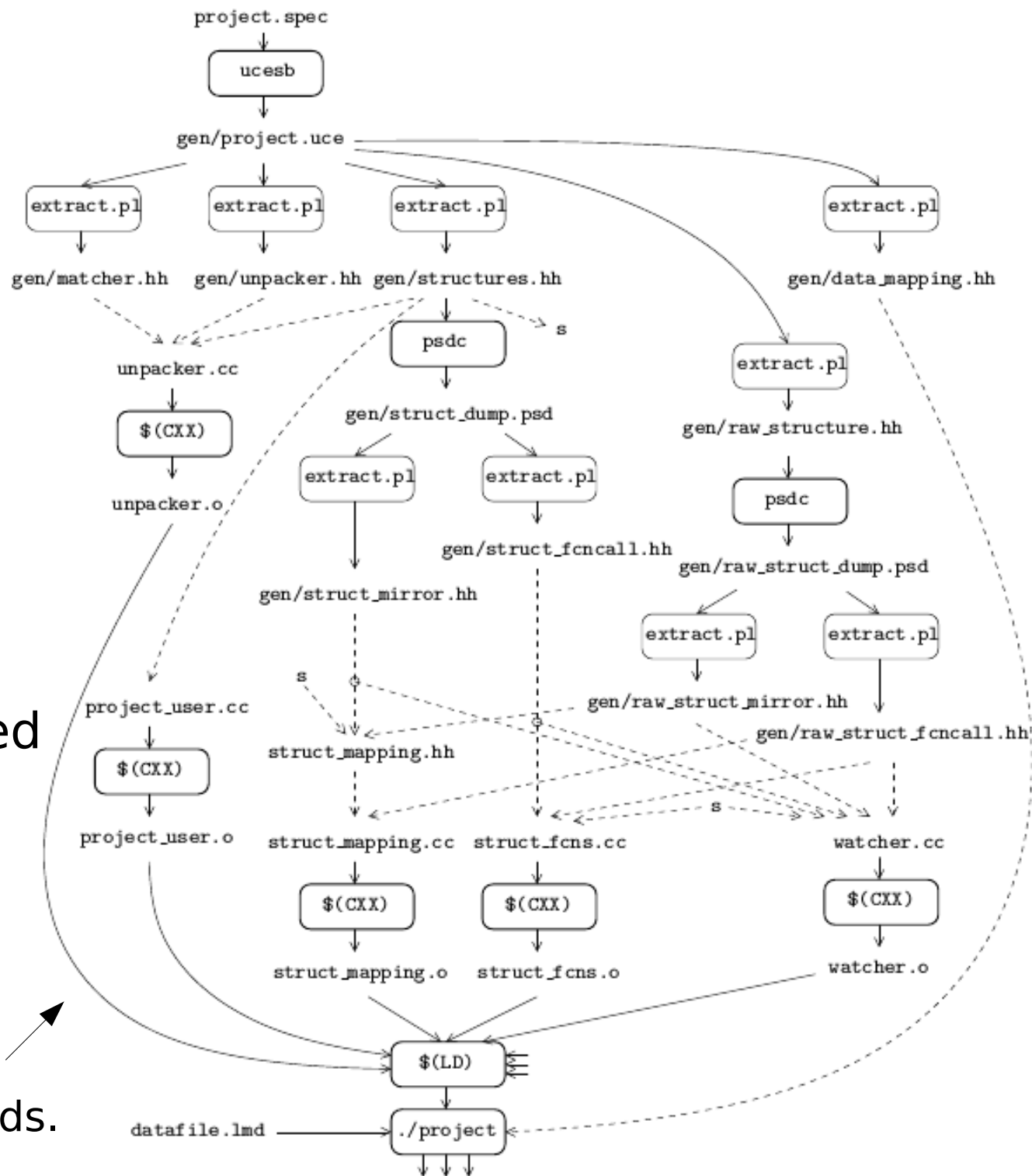

Watcher – the DAQscope

Thu Sep 27 10:49:39 2001

Physics: 536
 Offspill: 175
 Tcal: 21
 Other: 30

Event: 8663685

```

POS1_1T 2..2 .4.1...2.11887562112...2.....825 1
POS1_2T 2..2 33.2...11.2249746431..2...2.....8.5 1
POS1_3T 2..2 3.2...2..11.27974642.12...2..2.....8.5 1
POS1_4T 2..2 32...2...2..2797563..2...2...2...2.....8.5 1
POS2_1T 2..2 3...121.21.693..1...2...2...2...2...2...8.5 1
POS2_2T 2..2 2...2...21259..2...1...2...2...2...2...825 1
POS2_3T 2..2 1..2...2..1397.2...2...1...2...2...2...835 1
POS2_4T 2..2 1..1..21.149812...2...2...1...2...2...835 1
POS1_1E 2..2 A74432.1.....++1 1
POS1_2E 7855 974.....++1 1
POS1_3E 3413 A64311.....++1 1
POS1_4E 8855 9652.....++1 1
POS2_1E 8855 96432.....++1 1
POS2_2E 7855 9764343232.1.....++1 1
POS2_3E 7855 976442212.....++1 1
POS2_4E 4523 A7542311.....++1 1
PIN1_1E 21.2 8578666541.....5.....1....++ 1
PIN2_1E 3..2 9548655541.1.....15..1.....2....++ 1
N1_1_1T 4225 2.2.2.2.1.213.2112...1221.....++ 1
N1_1_2T 42.5 ..11112.112.1.11312.2.2..22.11.....++ 1
N1_2_1T 4225 2.2.22.1.2.222.2.21..222.....++ 1
N1_2_2T 42.5 ..112.2.2.2.1.11212.2.2.121112.....++ 1
N1_1_1E 2... 46.52.1...2..1.....++ a
N1_1_2E
N1_2_1E
N1_2_2E
  
```

Each line is a histogram for one raw channel

Values are \log_2 of bin content

Stored zeros and overflow

Colour by most contributing trigger type

Spill synchronized





--watcher=POS1-2_1-4T:POS1-2_1-4E:PIN1-2_1E:N1_1-2_1-2T:N1_1-2_1-2E

Correlation plots – EuroSuperNova (ESN) @KVI MWPC maps

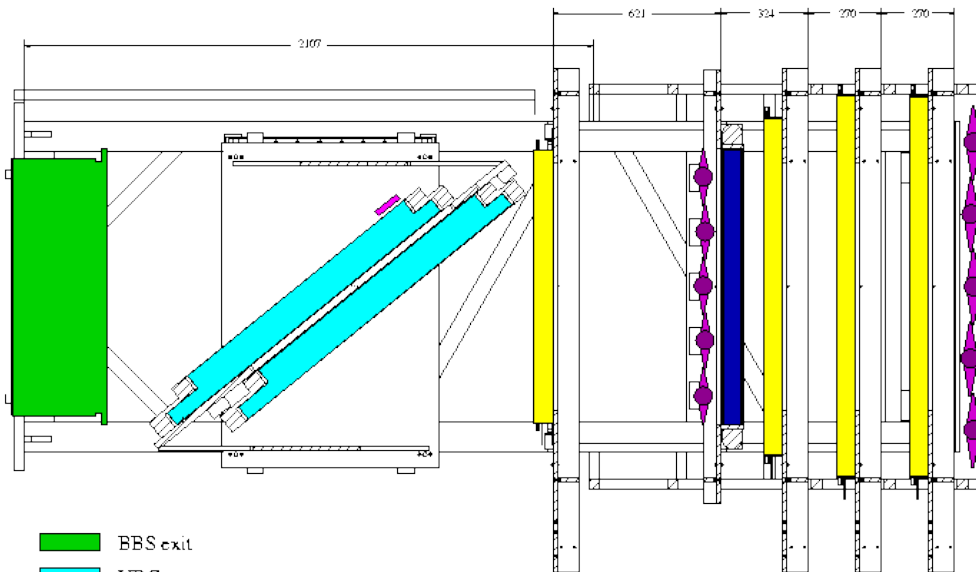
Every row/column =
1 channel

Intensity = $\log_2(\# \text{coincidences})$



-  BBS exit
-  VDCs
-  MWPCs D1-D4
-  Scintillators S1 & S2
-  Analyzer C

<http://www.kvi.nl/~snovadoc/>

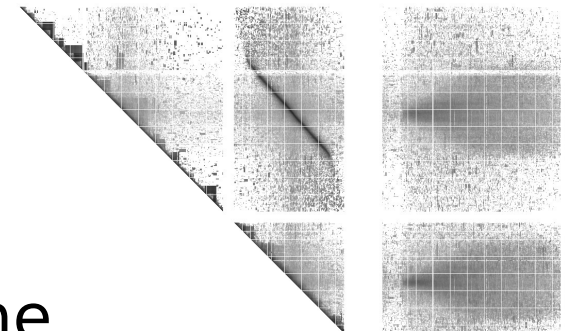
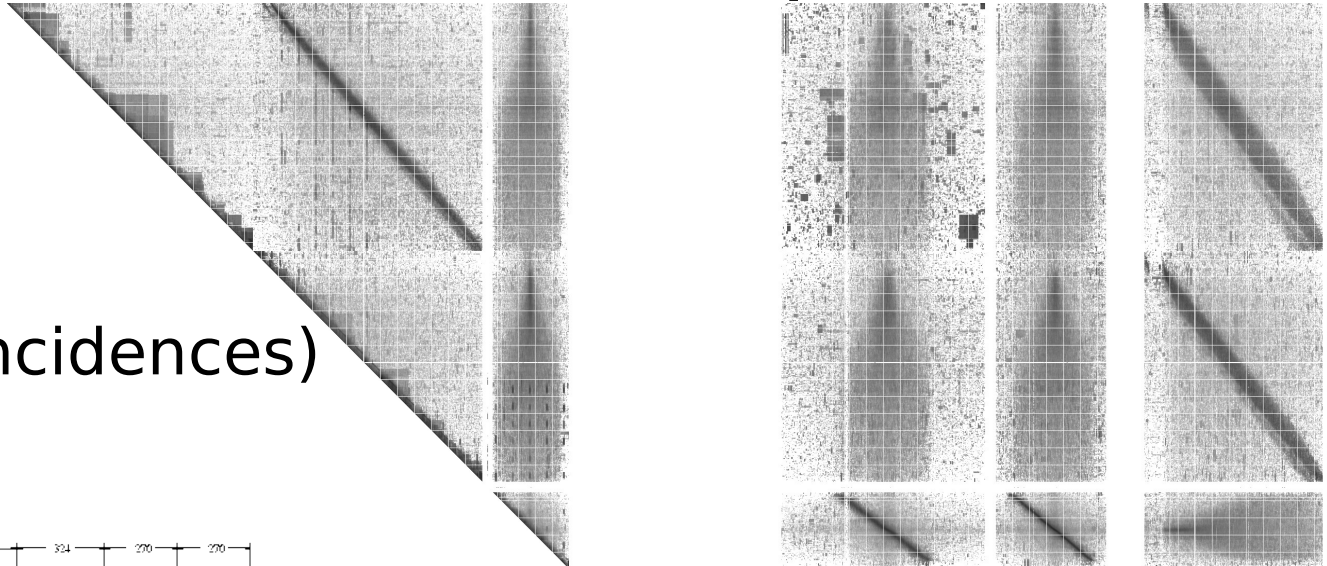

Plot shows the
~2500 active channels
of 32k possible

Quickly finding LAND cable mismap

8-fold cable
documentation
problem

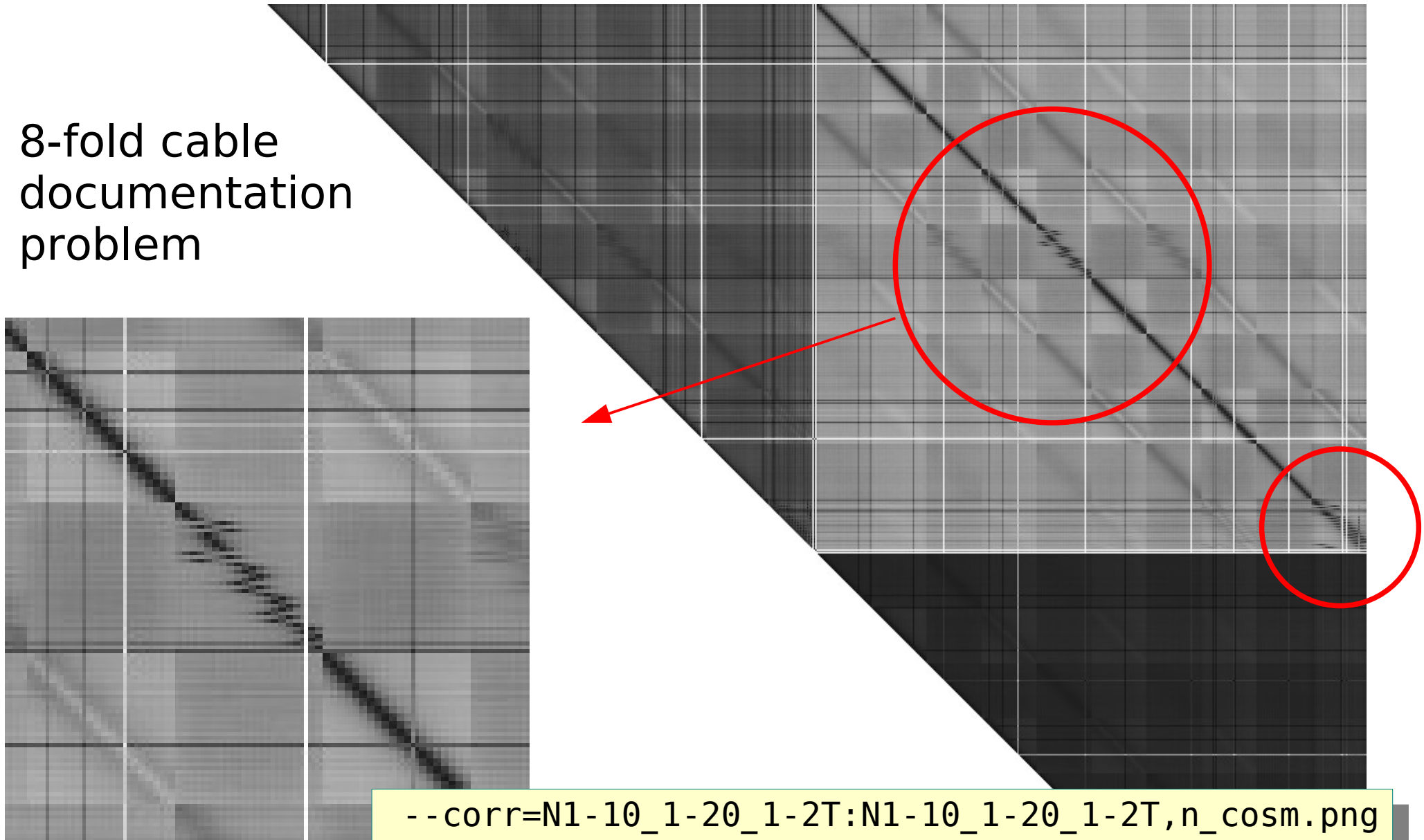

--corr=N1-10_1-20_1-2T:N1-10_1-20_1-2T,n_cosm.png

ntuple & ROOT tree generation

Select which **data-levels** to include.

Optionally limit which **detectors / channels** are included (also with **indices**).

Output file **type** selected by **extension**.

```
--ntuple=UNPACK, file.ntu  
  
--ntuple=RAW, file.ntu  
  
--ntuple=UNPACK, RAW, file.root  
  
--ntuple=RAW, POS2, N, TFW, TOF, file.root  
  
--ntuple=UNPACK, fastbus, camac, file.root
```

Pipelining

Left | as | exercise | to | the > reader

ucesb interaction

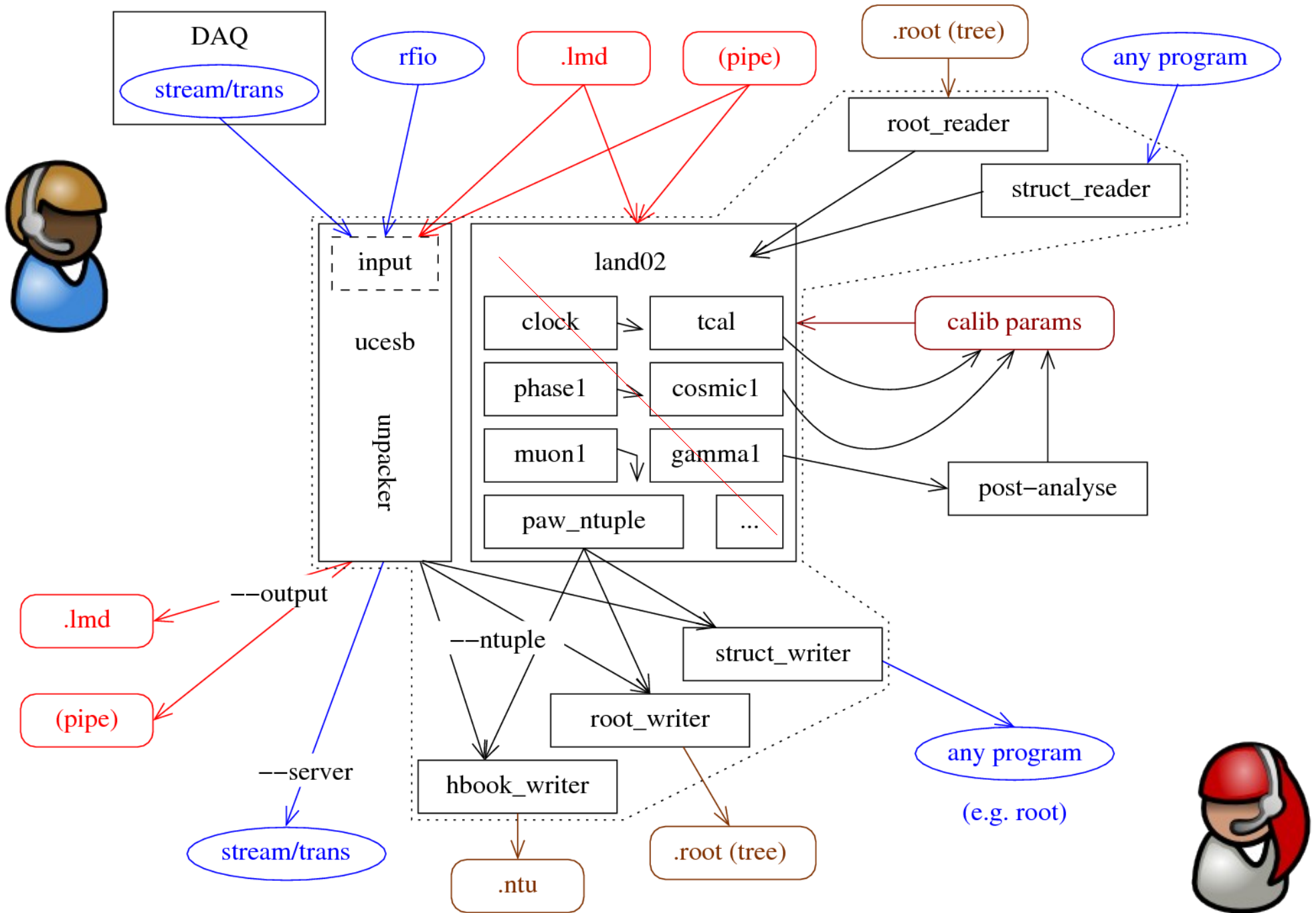

'Any' program processing

```
#include "ext_data_client.h"
#include "ext_h101.h"
#include <stdlib.h>
#include <stdio.h>

int main(int argc, char *argv[])
{
    struct ext_data_client *client;

    EXT_STR_h101 event;
    EXT_STR_h101_layout event_layout = EXT_STR_h101_LAYOUT_INIT;

    if (argc < 2)
    {
        fprintf (stderr, "No server name given, usage: %s SERVER\n", argv[0]);
        exit(1);
    }

    client = ext_data_connect_stderr(argv[1]);

    if (client == NULL)
        exit(1);

    if (ext_data_setup_stderr(client,
                             &event_layout, sizeof(event_layout),
                             sizeof(event)))
    {
        for ( ; ; )
        {
            if (!ext_data_fetch_event_stderr(client, &event, sizeof(event)))
                break;

            /* Do whatever is wanted with the data. */

            printf ("%10d: %2d\n", event.EVENTNO, event.TRIGGER);
        }
    }
    ext_data_close_stderr(client);
    return 0;
}
```

Using the same structures as generated (virtually) for ntuples and ROOT trees

'Any' program processing

```
empty/empty /dev/null \  
--ntuple=UNPACK,STRUCT_HH,ext_h101.h
```

```
typedef struct EXT_STR_h101_t  
{  
    // UNPACK  
    uint32_t TRIGGER;  
    int32_t  EVENTNO;  
} EXT_STR_h101;
```

*Also as network
server (any # clients)*

```
cc -g -O3 -o ext_reader_h101_stderr -I. ext_data_reader_stderr.c hbook/ext_data_client.o
```

```
empty/empty INFILE.lmd --ntuple=UNPACK,STRUCT,- | \  
./ext_reader_h101_stderr -
```

Finale!

A great deal of **FUN?**

Thank you!

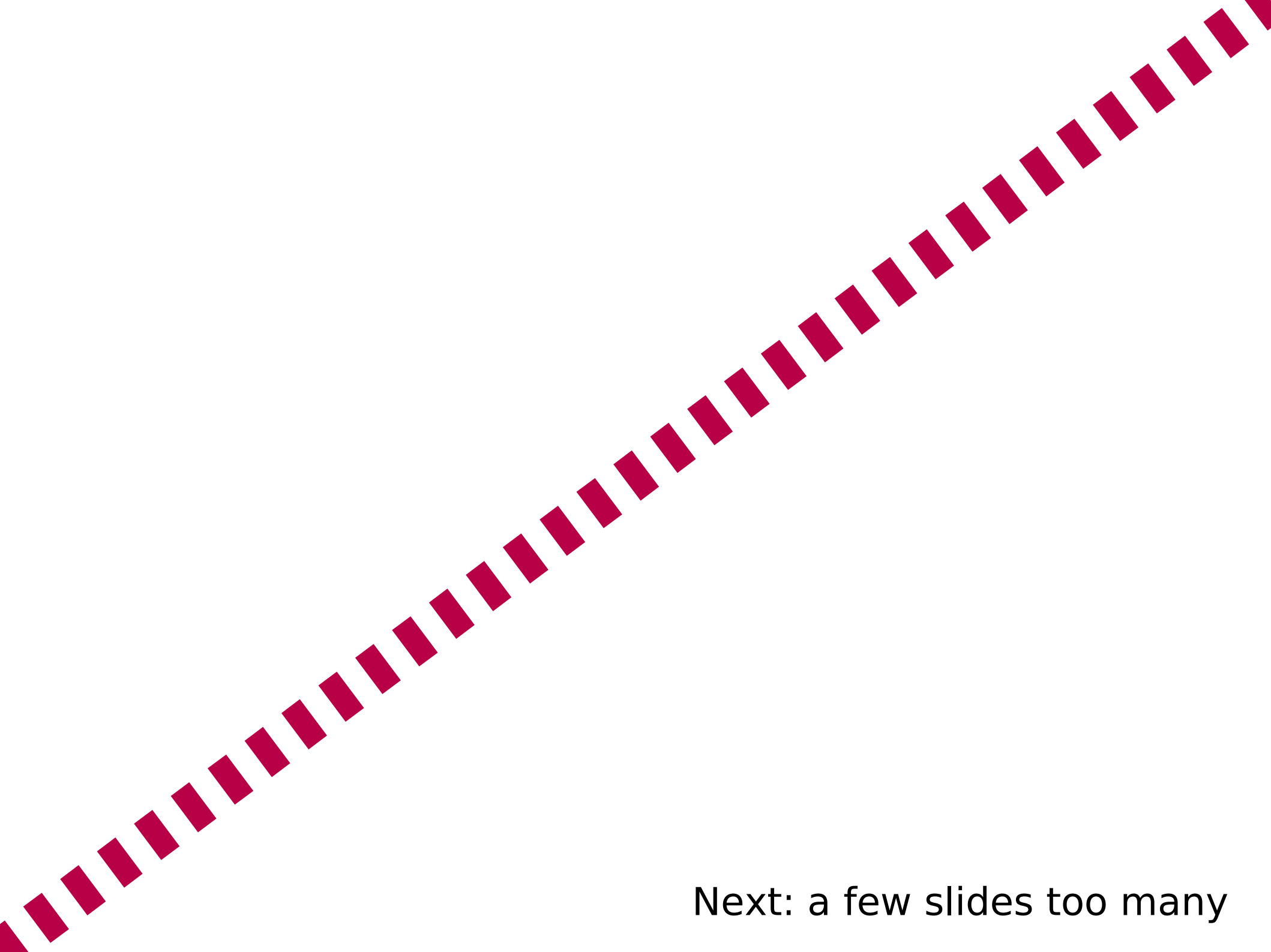

Next: a few slides too many

Command line – Output options

<code>--output=OPT,FILE</code>	Save events in LMD file (native/net/...,size=nM).
<code>--bad-events=FILE</code>	Save events with unpack errors in LMD file.
<code>--server=OPT</code>	Data server (stream:port,trans:port,size=nM,hold).
<code>--ntuple=LVL,DET,FILE</code>	Dump data as PAW/ROOT ntuple.

Events can be written to **new files**

Creation of **new** sub-events

Events and sub-events can be **selectively** included

For pipelines, `-` is treated as STDOUT

Store events with **unpack errors**

(useful for DAQ diagnostics with on-line input)

Act as **on-line** data **servers**

(as proxy or from file / any input for dry-run tests)

Write data to **HBOOK ntuples**, **ROOT trees**,
or (any) **external program**

Command line – Error handling

```
--allow-errors  
--broken-files  
--debug  
--io-error-fatal
```

Allow errors.

Allow errors again after bad files.

Print events causing errors.

Any I/O error is fatal.

UCESB unpackers normally **abort** after **10 errors**

Processing can continue after **broken files**

0xHEX-dump the **raw data** for broken events

Command line – Miscellaneous

```
--show-members  
--calib=FILE  
--max-events=N  
--help
```

Show members of all data structures.

Extra input file with mapping/calibration parameters.

Limit number of events processed.

Print this usage information and quit.

Print a **list** of all available **variables**:

```
UNPACK_vme_tdc3data32      .UNPACK.vme.tdc[3].data[z:32]  
UNPACK_vme_tdc3eob_u32    .UNPACK.vme.tdc[3].eob.u32  
UNPACK_vme_scaler0_data32 .UNPACK.vme.scaler0.data[z:32]  
UNPACK_vme_scaler0_header_u32 .UNPACK.vme.scaler0.header.u32  
UNPACK_vme_adc5data32     .UNPACK.vme.adc[5].data[z:32]  
UNPACK_vme_adc5eob_u32    .UNPACK.vme.adc[5].eob.u32  
UNPACK_vme_header_failure_u32 .UNPACK.vme.header.failure.u32  
UNPACK_vme_header_time_stamp .UNPACK.vme.header.time_stamp  
UNPACK_vme_header_multi_events .UNPACK.vme.header.multi_events  
...  
RAW_BACK2E                .RAW.BACK[2].E  
RAW_MONE_E                .RAW.MONE.E  
RAW_MONDE_E              .RAW.MONDE.E  
RAW_MONTGT_E             .RAW.MONTGT.E  
RAW_DSSSD2F32E           .RAW.DSSSD[2].F[z:32].E  
RAW_DSSSD2F32T           .RAW.DSSSD[2].F[z:32].T  
RAW_DSSSD2B32E           .RAW.DSSSD[2].B[z:32].E  
RAW_DSSSD2B32T           .RAW.DSSSD[2].B[z:32].T  
RAW_DSSSD2FT             .RAW.DSSSD[2].FT  
RAW_DSSSD2BT             .RAW.DSSSD[2].BT  
...
```

Simple **linear calibrations** at RAW → CAL conversion

Stop processing after **N** events.

Too many options?

Anatomy of raw data files (.lmd)

Each **file** has many **events**:
a **header**, and...

Each **event** has one or more **sub-events**:
a **header**, and...

Each **sub-event** has data from acquisition **modules** (TDCs, QDCs, ADCs, scalers...):
often a **header** per module, and...

Each **data word** is a value, sometimes
with **indexing** information

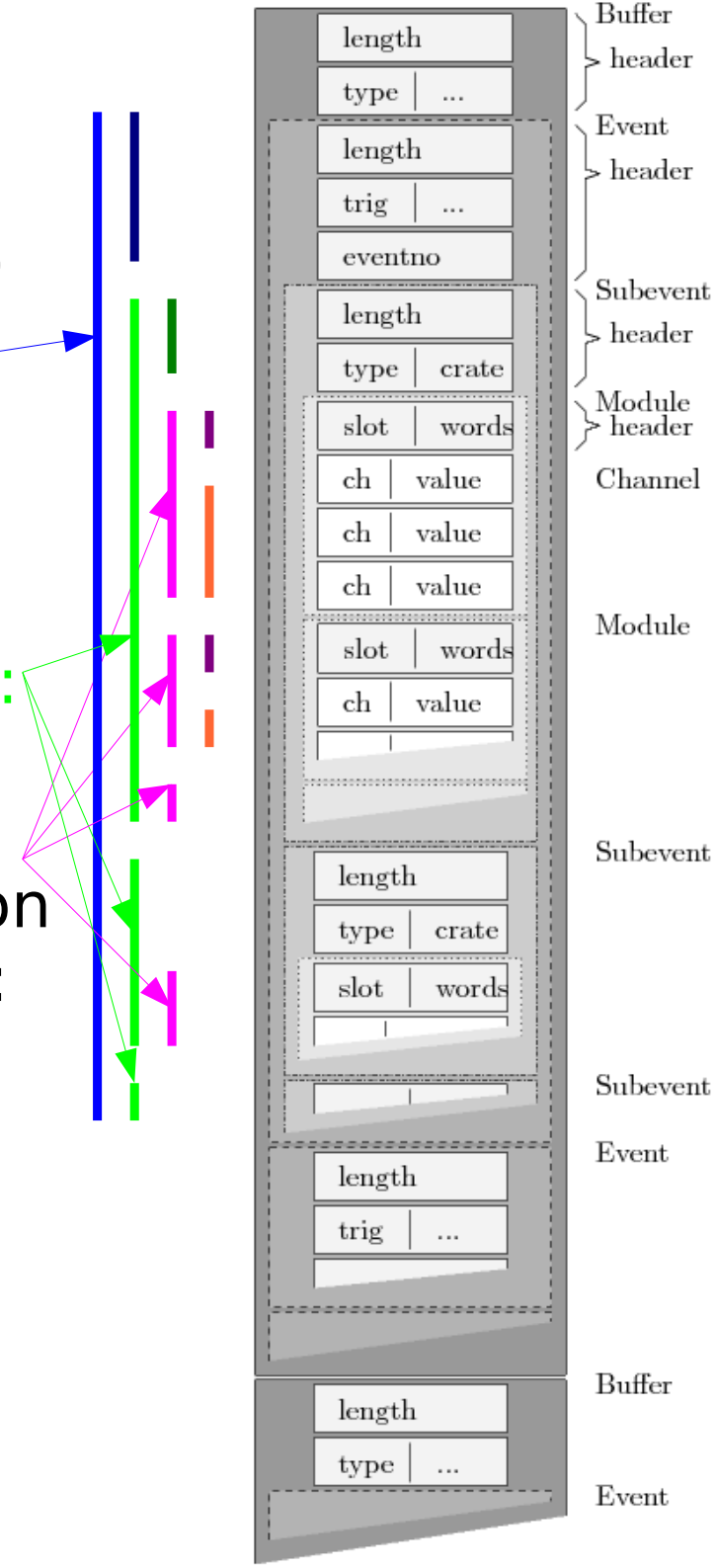

.spec: zero-suppression, NOENCODE

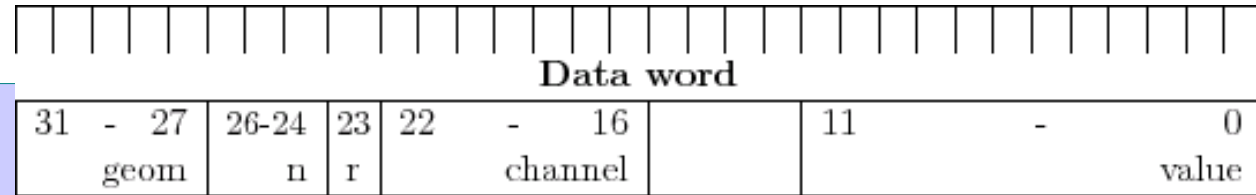

```
LECROY_1885(geom, channels)
{
  MEMBER(DATA12_RANGE data[96] ZERO_SUPPRESS);

  UINT32 ch_data NOENCODE
  {
    0_11: value;
    16_22: channel = RANGE(0, channels);
    23: range;
    24_26: n = 0;
    27_31: geom = MATCH(geom);

    ENCODE(data[channel], (value=value,
                           range=range));
  }
}
```

```
class LECROY_1885
{
  raw_array_zero_suppress <
    DATA12_RANGE,
    DATA12_RANGE, 96 > data;
};
```

NOENCODE data words are consumed by the generated unpacker

```
SUBEVENT(FASTBUS_CRATE) {
  select several {
    adc = LECROY_1885(geom=10,
                     channels=64);
  }
}
```

The same module can be entered many times: revisit / or not: norevisit

usually without module header usually with header

.spec: lists and conditionals

```
GROUP_DATA(group)
{
  MEMBER(DATA16 data[64] NO_INDEX_LIST);

  UINT16 header NOENCODE
  {
    0_7:  group = MATCH(group);
    8_13: item_count;
    14_15: 0b01;
  }
  list (0 <= index < header.item_count)
  {
    UINT16 value NOENCODE;

    ENCODE(data APPEND_LIST, (value=value));
  }
  if (!(header.item_count & 1))
  {
    // Padding needed to keep 32-bit alignment
    UINT16 pad NOENCODE { 0_15: 0; }
  }
}
```

Use a list when the number of items is known



Conditional



Byte swapping - endianness & scrambling

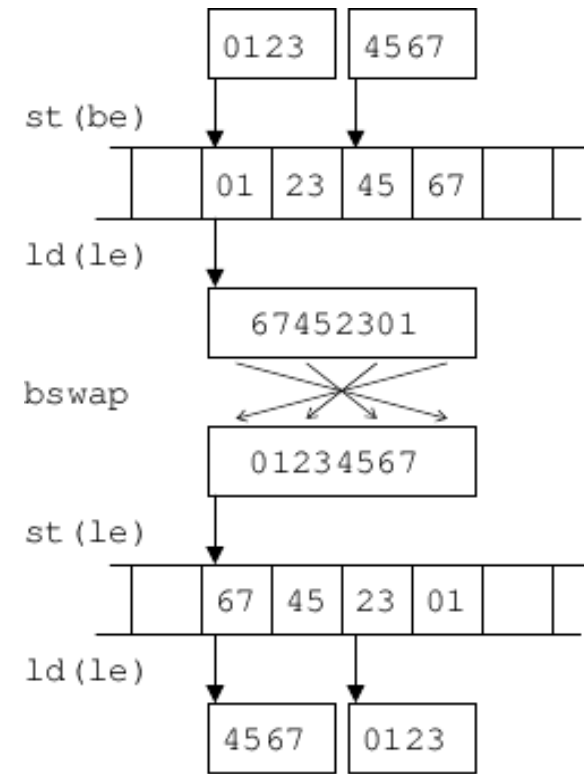
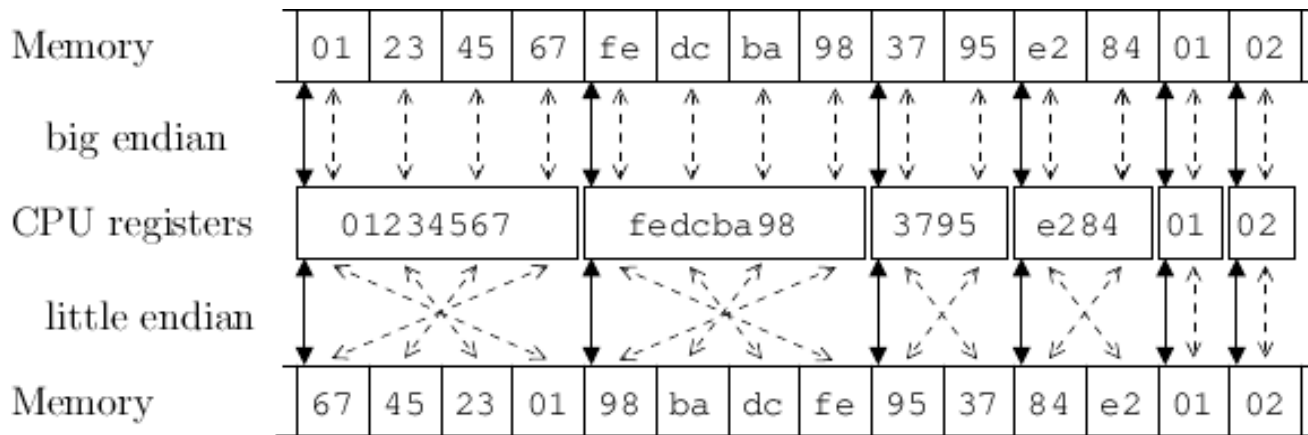

Endianness differences and byte-swapping are unavoidable → deal with it → markers!

UCESB knows what to do!
(given marked file formats... - workaround for others)

Byte-swapping with the wrong size scrambles the data

st = store (CPU → memory)
ld = load (memory → CPU)
be = big endian
le = little endian

Zero-suppressed mappings

```
struct raw_event_DETC_FRONT
{
    DATA12 T;
};
struct raw_event_DETC
{
    raw_array_zero_suppress < raw_event_DETC_FRONT,
                             raw_event_DETC_FRONT, 16 > FRONT;
};
struct raw_event
: public raw_event_base
{
    raw_event_DETC DETC[2];
};
```

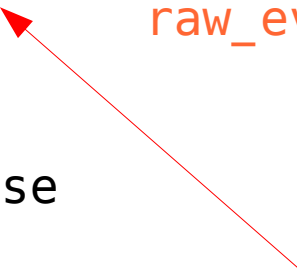

Templated encapsulation-classes implement **zero-suppression**

```
// A list of mappings/items
SIGNAL(DETC_2_FRONT_1_T, vme.tdc[2].data[0],
       DETC_2_FRONT_16_T, vme.tdc[2].data[15], DATA12);

// Make an array zero-suppressed
SIGNAL(ZERO_SUPPRESS: DETC_1_FRONT_1);
```

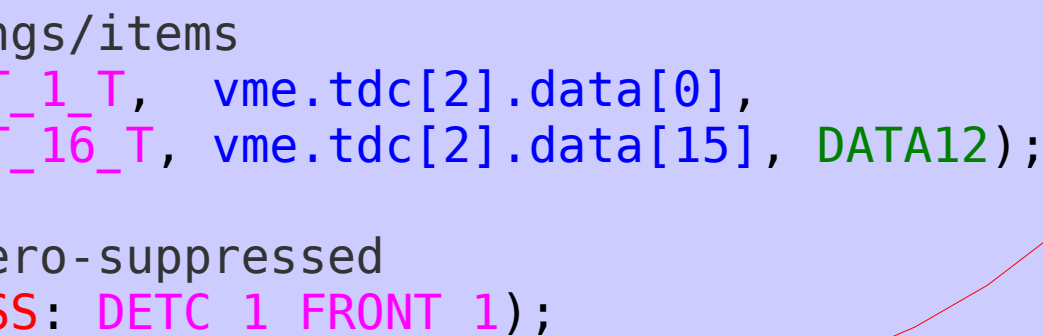

Correlation plots – ESN VDC maps

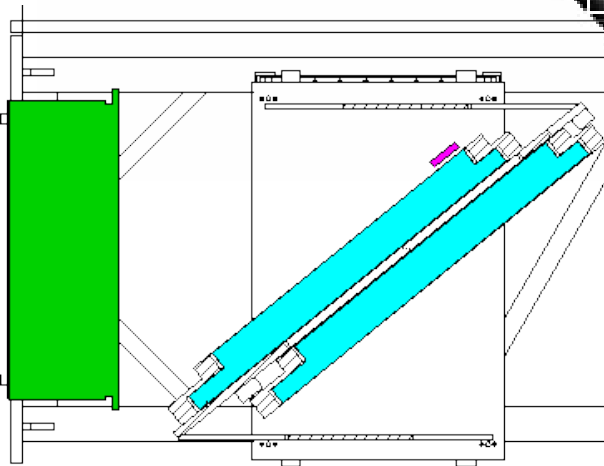
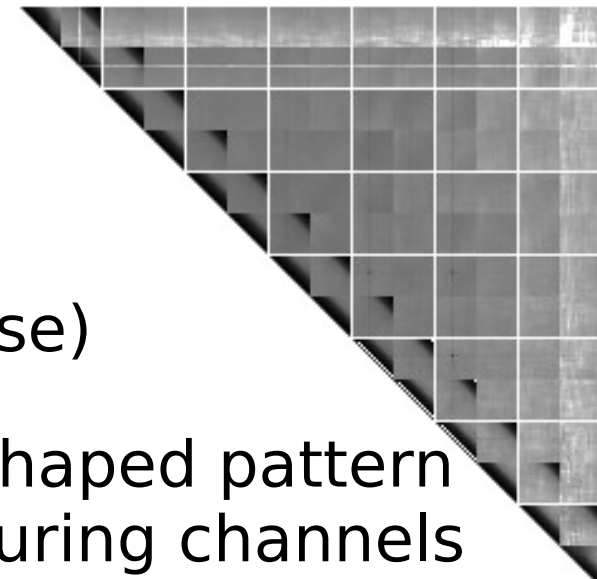
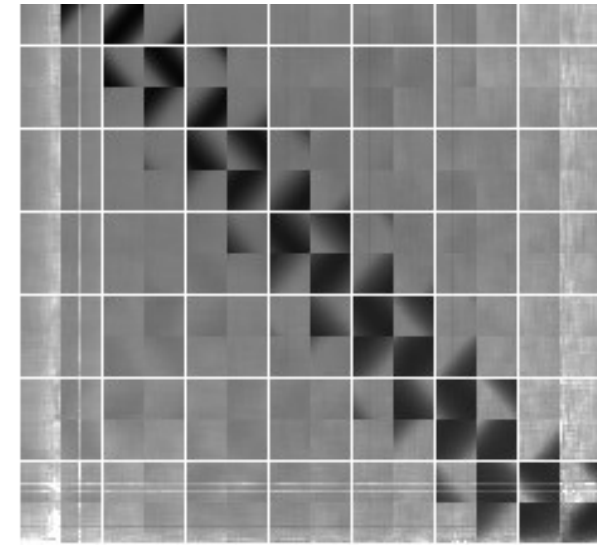
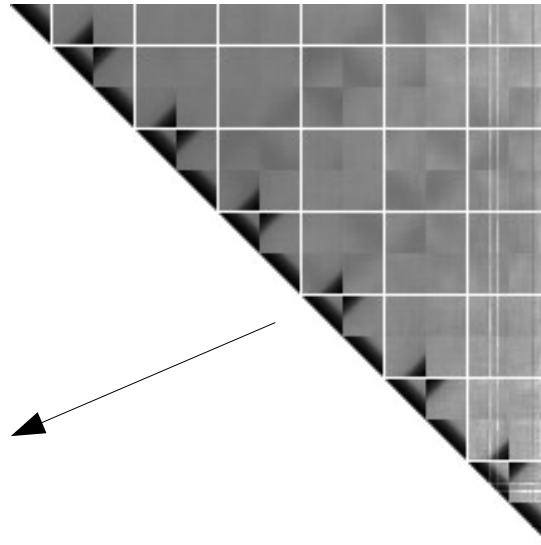
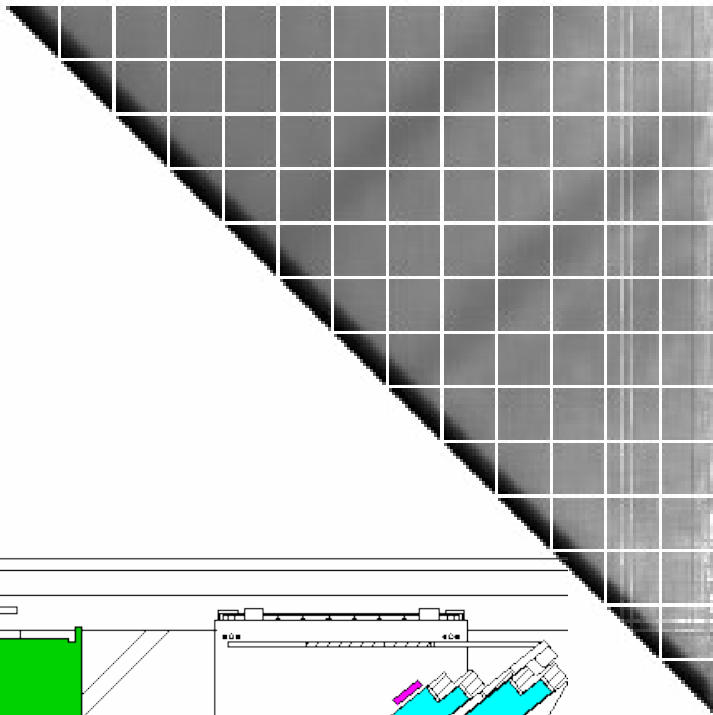

■ BBS exit
■ VDCs

Every second 16-fold cable inverted (on purpose)

Every ion track gives V-shaped pattern (in time) in ~ 10 neighbouring channels

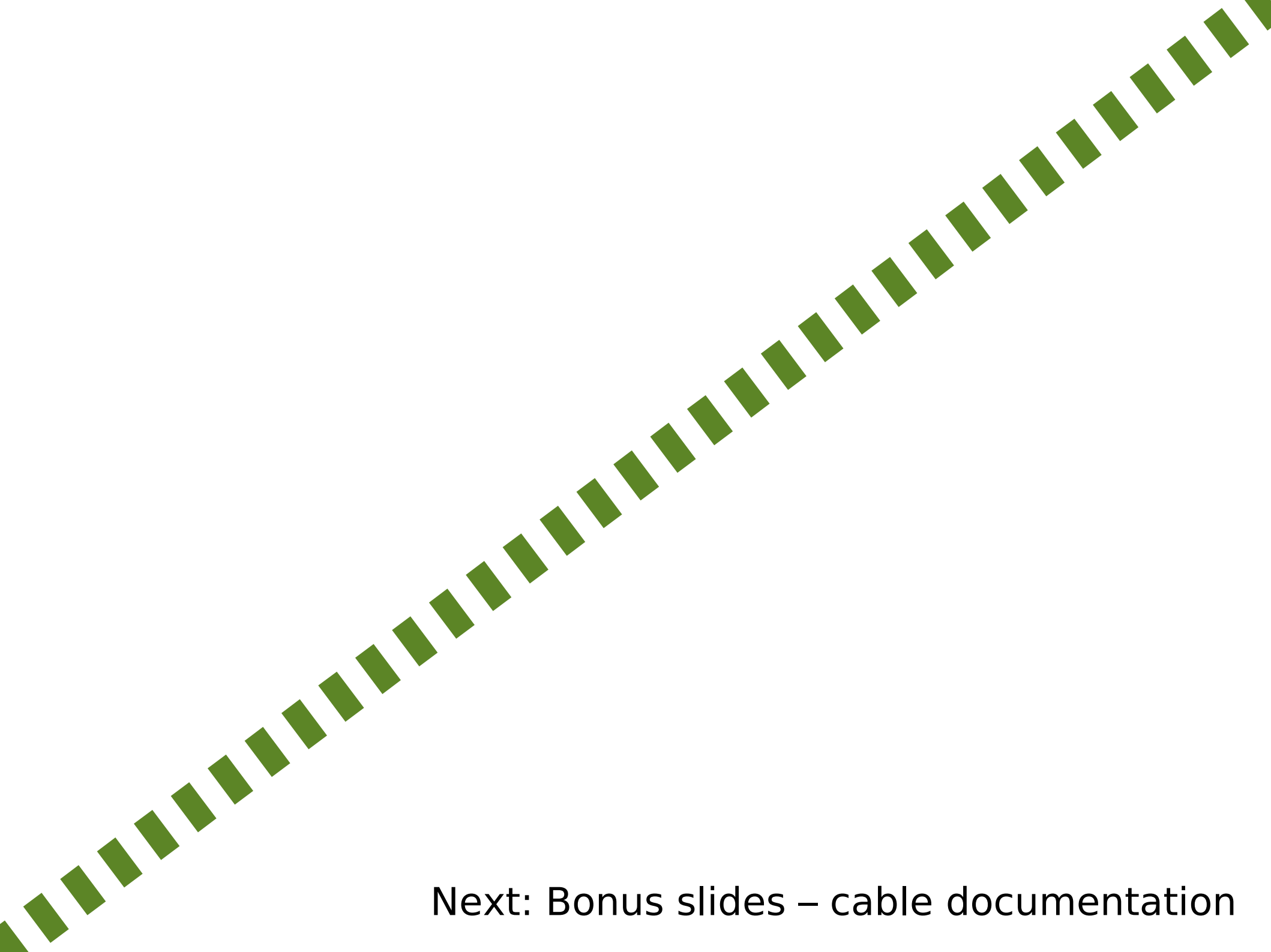

Next: Bonus slides – cable documentation

Just a few cables...

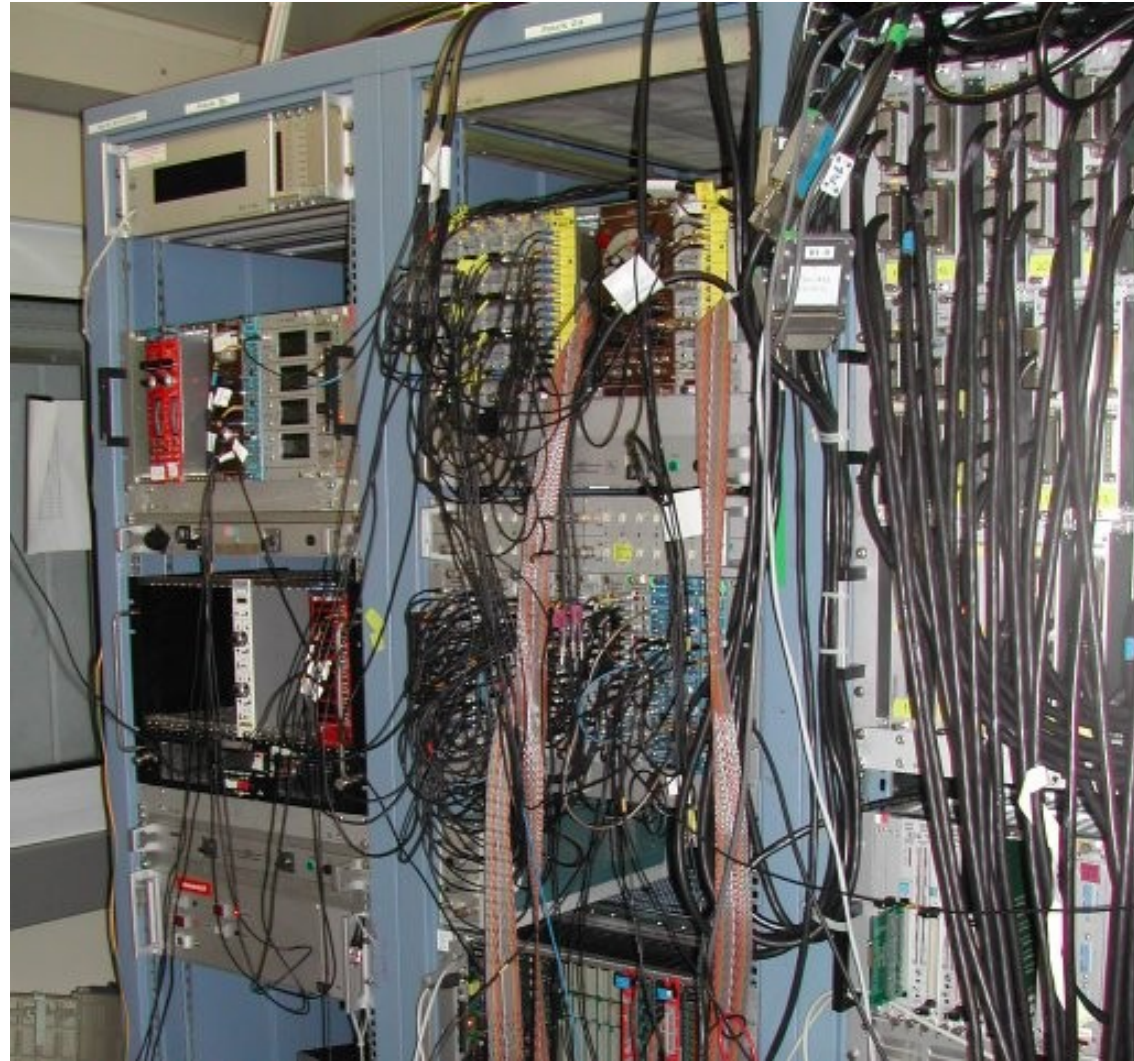

Solution / workaround ----->

Support tool: cable documentation

```
CF8103(r12c2s1)
```

```
{  
  SERIAL("LCF6343"); // Comments
```

```
  in1_8: "N11 CFTN1" <- , r13c1s1(SPLIT)/t1_8;  
  th1_8: "1/1"         -> , r11c1s1(SCALER)/in0_7;  
  tb1_8: "CR2 SL1"    -> , .s15(DELAY)/in1_8;
```

```
  m:      .c11s3/in1;  
  test:   .s23/out1;  
  mux_tb: .s22/in1a;  
  mux_e:  .s22/in5a;  
  mux_mon: .s22/in9a;  
}
```

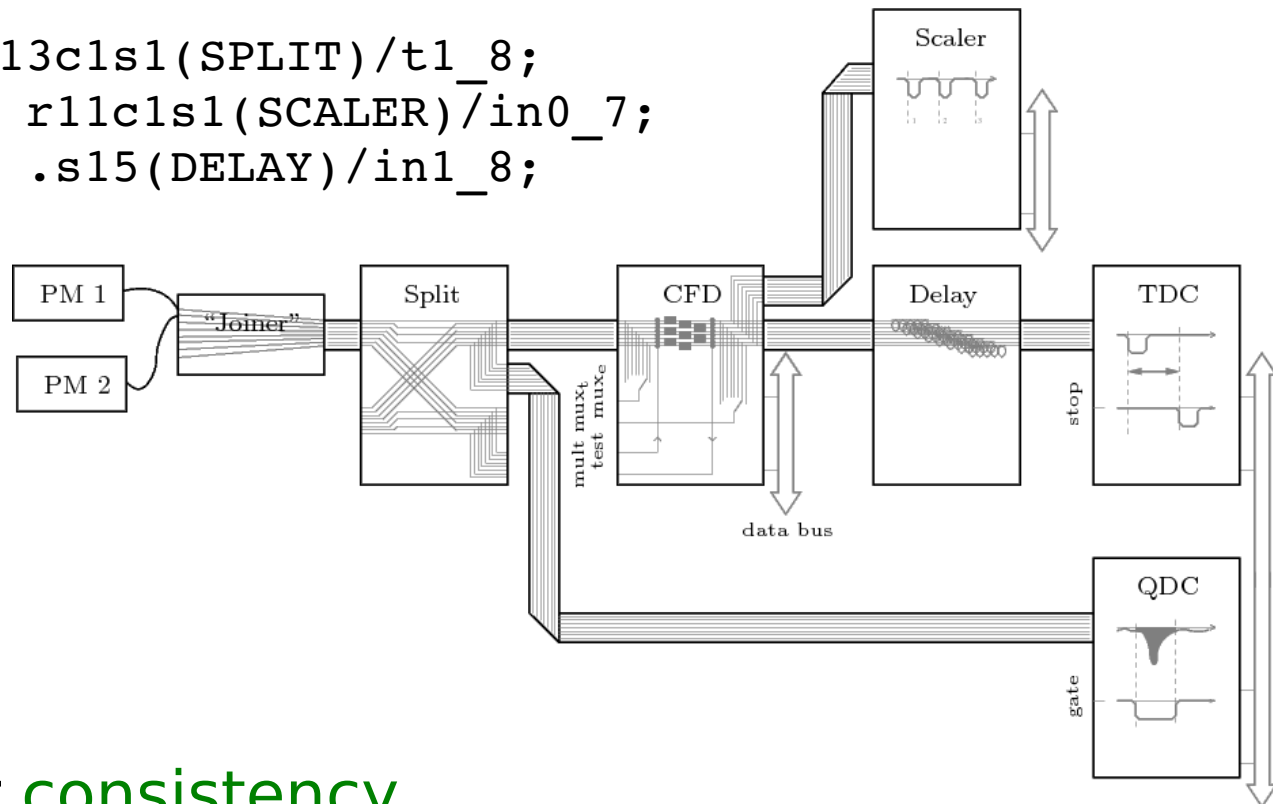

C-like text format.

Parsed and checked for consistency.

(Every cable documented twice – at both ends.)

Checker generates tables for unpacking and slow-control.

S304 cable doc

Electronics chain for



the ALADiN
TOF wall



1 PhD, < 1 week
(= a few days)

→ working unpacking
and mapping

